

 **Sealed Air**

Shanklin®

Shrink Packaging Machinery

Hy-Speed Servo SS DA Wrapper

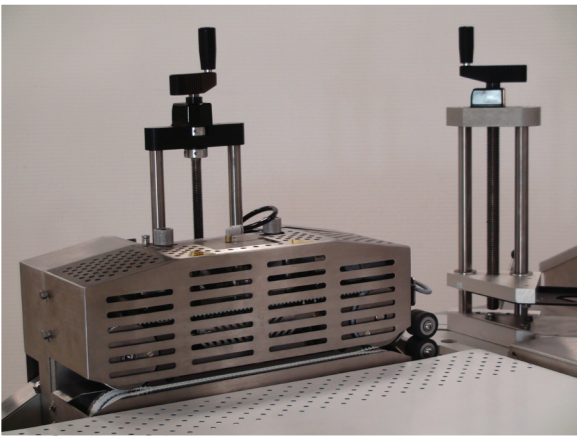
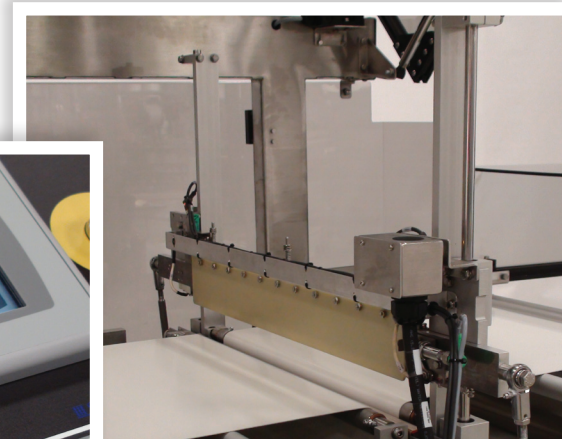

**Cryovac®
Technology**

*Meeting Sustainable Packaging Needs
Without Compromising Performance Or Value*

Sealed Air Sustainability



Shanklin[®] Hy-Speed Servo SS DA

SS (Side Seal) DA (Stainless Steel Construction With Removable Washdown Infeed)

General Specifications

- Up to 180 ppm (product and film dependent)
- Film/belt speed @ up to 250 ft/min
- Engineered for smooth operation
- 0 – 8.5" End Seal opening
 - Adjustable to variable heights
 - Toolless End Seal centerline adjustment
- 23" wide End Seal
- Choice of Smartwire™ or Hot Knife End Seal
- Programmable seal pressure
- Package dimensions
 - Up to 19" width
 - 4" to 48" length (flighted configuration)
 - Up to 8" height ("true" product height)
 - Package height plus width not to exceed 23"
- Maximum film width (Side Seal Config.)
 - 33" Centerfold
 - 60" Flat (with Centerfolder)
- Sabre Side Sealer
- No Product No Bag Feature
- Pass through conveyor capability
- Standard conveyor height
 - 41 ½ with Casters
 - 35 ½ without casters
- CAT 3 Emergency Stop Circuits
- Multiple safety interlocks
- Air cylinder safety opens end seal jaws

HMI (Human Machine Interface) Features

- Picture based display
- Recipes— 100 nameable recipes
- Speed control adjustments
- Product spacing
- Seal systems temperature control
- End Seal cut Enable/Disable
- Programmable seal pressure
- Operator Lock Outs provide customized HMI access privileges
- Batch counting
- Language switching - 9 languages
- Metric/Imperial unit switching
- Remote Monitoring via HMI Web Server
 - Monitor production information
 - View machine fault logs
 - Analyze machine status
- Integrated auxiliary infeed ready
 - Infeeds controlled thru HMI
 - Speed ratios recallable thru recipes
- External Equipment Pause allows up/downstream equipment to pause wrapper
- Enhanced Troubleshooting Screens
 - Fault history
 - Input/Output status
 - Seal heat troubleshooting
 - Help and Corrective action screens
- Jaw product detect (optional)
- Low/Out of film (optional)
- Print registration (optional)

Electrical Specifications

PLC: Allen Bradley Compact Logix L33 ERM

HMI: Allen Bradley Panelview Plus 700

Servos: 5 Axis, AB Kinetix 350 Drives

- Infeed
- Side Seal Belt and Sealer
- End Seal Belt
- Carriage Motion Control
- Jaw Closure

Utilities

- 230V, 60Amp, 50/60 Hz, 3 Phase
- 1/2 C.F.M. moisture free air at 60 psi

Plan View →

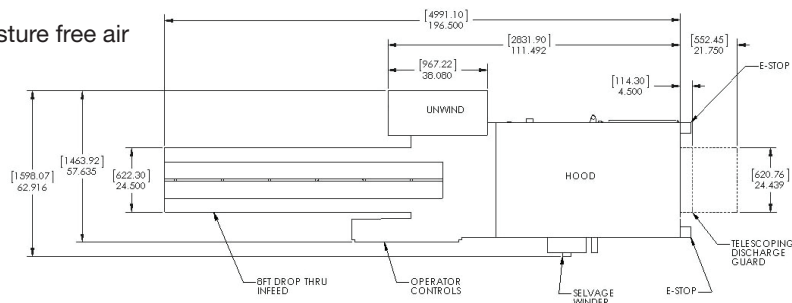

Distributed by:



Shrink Packaging
100 Rogers Bridge Road
Duncan, SC 29334
866-773-4567 Fax: 864-433-2019
www.shrinkfilms.com

Our Products Protect Your Products[®]

Corporate Offices: Sealed Air Corporation
200 Riverfront Blvd, Elmwood Park, NJ 07407 www.sealedair.com
© Reg. U.S. Pat. Off. © Sealed Air Corporation 2012. All Rights Reserved. Printed in the USA.
The "9 Dot Logo" and "Sealed Air" are registered trademarks of Sealed Air Corporation (US).