

# 2-EZ<sup>®</sup> HM/2-EZ<sup>®</sup> HS HM

## Case Erector / Bottom Hot Melt Seal



For optimal durability, reliability and value, the Combi 2-EZ<sup>®</sup> HM and 2-EZ<sup>®</sup> HS HM are your clear choice for case erecting and bottom sealing with hot melt glue. Built with the industry's strongest frame (*lifetime warranty*) for the most demanding 3-shift environments, these case erectors readily integrate into your existing line. The systems' design featuring Combi's EZ-load walk-in case magazine, Nordson ProBlue Glue Unit and quick changeover system assures minimal downtime and years of dependable service. As all Combi 2-EZ<sup>®</sup> case erectors, these versatile machines can form and seal the widest variety of cases, from single wall to triple wall corrugated. Add the Combi 2-EZ<sup>®</sup> HM to your line for instant productivity.

### Features:

- Speeds 12 to 20 cases per minute
- EZ Load Walk-In Case Magazine
- Compact, Heavy duty, Welded Steel Construction
- Mechanical Four Flap Closing
- Nordson ProBlue<sup>®</sup> Melters Glue System
- Self-cleaning vacuum system
- Allen-Bradley PLC Control

### Benefits:

- Increased productivity
- No reaching or top loading that can lead to shoulder or back strain
- Rugged; lifetime guarantee on framework
- Ensures square, secure cases every time
- World's leading producer of precision dispensing equipment
- Prevents corrugated dust from building up in vacuum suction cups
- Industry standard for integrated control and information platforms and intelligent motor control



**2-EZ HM**

*with optional Powered Case Magazine*

## Sequence of Operation:

The flat case stands vertical in the magazine. The case is extracted from the magazine and initially formed by the squaring arm. The rear minor flap is rotated to 90°, and the front flap is plowed closed. The major flaps are positively closed by separate rotary actuators as the case is indexed to the compression station. The glue is applied to bottom case flaps and the case is sent to the compression station where it is sealed.

## Electrical Service:

240 volt / Three Phase / 60 Hz / 20A

## Air consumption:

80 psi, 5.4 cfm @ 12 cpm

Model	Case Size Min. (LxWxH)	Case Size Max. (LxWxH)	Speed: Cases Per Minute*
2-EZ <sup>®</sup> HM Pneumatic	8 x 8 x 5" (152x114x114mm)	24 x 16 x 18" (610x406x457mm)	12 cpm 21-24" Long 17 cpm
2-EZ <sup>®</sup> HS HM Servo	8 x 8 x 5" (152x114x114mm)	24 x 16 x 18" (610x406x457mm)	up to 20

\* Speed is case size dependent

2-EZ HM

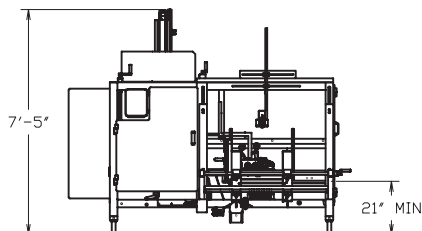
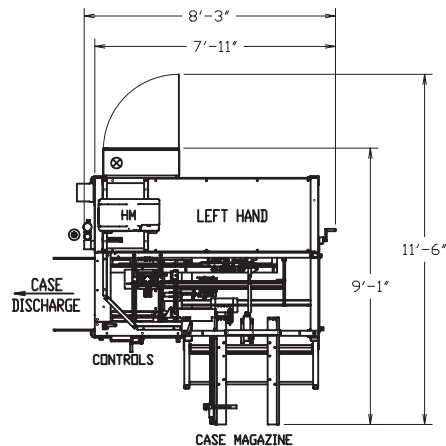

Compression ensures tight, secure seals on the widest range of case sizes and styles:

- RSC Regular Slotted Case
- CSSC With Meeting Minors
- RSC with 5th Panel Partition
- AFM All Flaps Meeting
- FOL Full Overlapping Flaps
- RSC with Reversed Glue Flaps

Distributed by:

**Combi**  
Packaging Systems LLC

5365 East Center Dr. NE Canton, OH 44721  
Phone: 1-800-521-9072 Fax: 330-456-4644

www.combi.com  
© 2015 Combi Packaging Systems LLC  
a joint venture company with 3M and M J Maillis Group